

Instructions for installation & maintenance

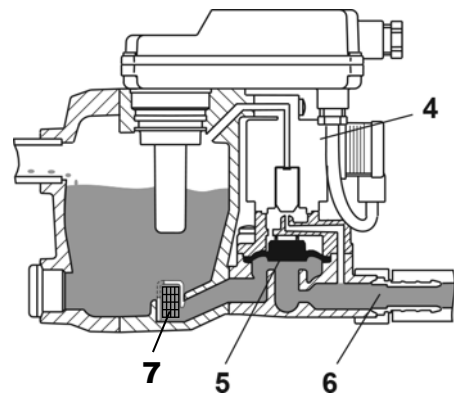

STELSEP ZL1300 & ZL5000 are manufactured in various specifications for use in different markets across the world. Please ensure you take account of local regulations while installing and using the auto-drain, and always check pressure and voltage options are correct for your application before selecting or using the product.

Functional description

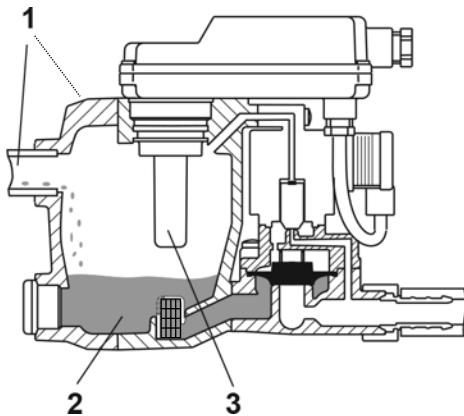

The drain should be connected to a condensate drainage point (1) so that its reservoir (2) will collect condensate. Reaching a pre-determined level, the condensate triggers a capacitive (non-contact) sensor (3) that starts the drain sequence. The control PCB causes an electrical signal to operate the pilot valve (4), allowing system air pressure to lift the main valve's diaphragm (5) from its seat for condensate discharge.

As the reservoir level reduces, a second sensor triggers the control PCB, allowing system pressure to be re-applied above the main diaphragm causing it to shut off flow and preventing system air from being discharged to atmosphere through the condensate line. A strainer (7) is fitted in the outlet line to protect the main valve seat from damaging debris.

Installation pointers

The inlet pipe must slope downwards to the drain. Water traps (low spots) must be avoided to prevent air-locks which will prevent drain from working

Where possible, connect to the top inlet (ZL5000 only) or upper front inlet (all models). If lower inlet must be used to maintain slope, take an air 'balancing line' to a suitable point in the air system such as the tank's pressure gauge.

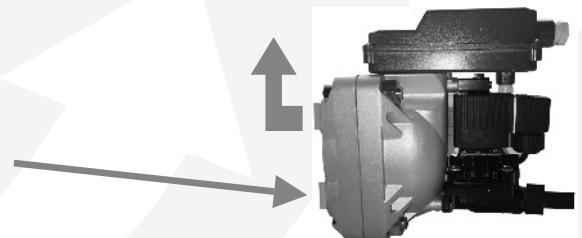
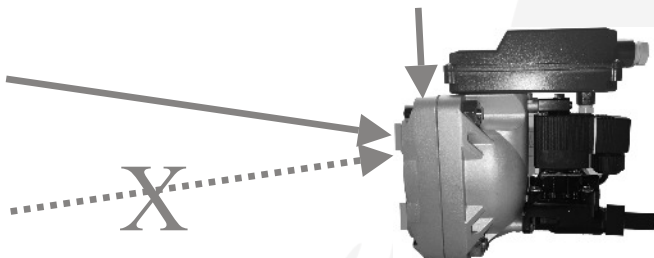

When the ZL1300/ZL5000 drain is collecting condensate, any air displaced by the rising liquid level has to be able to return to the air system. Normally it will travel along the inlet pipe in the reverse direction to the condensate flow. If the lower inlet is used, or there is a low spot in the pipe, collected liquid will block this route - so a balancing line is essential

This is a requirement of all such drains, and of course does not waste air as it remains a closed system. If the inlet connection is near vertical, flexible pipe can be used, provided it is well supported and low spots are not allowed to form, which would prevent the necessary air displacement.

Electrical Installation

Please check the supply voltage before starting, and carry out any work in accordance with your appropriate local regulations.

Remove cover (4 screws). Bring power cables through the cable glands and lid apertures and then connect to marked terminals L,N,PE. on the central terminal block.

If potential-free remote alarm contacts (RA version) are being used, connect cable through glands and lid aperture as above, and connect across N/O or N/C terminal pairs as indicated on the board graphics on the right hand side terminal block (as viewed from the cable entry side

Refit lid & tighten screws sufficiently to ensure a good seal

Maintenance

ZL1300 / ZL5000 are both high quality products, carefully designed and engineered to give excellent service over an extended period of time.

However, they operate in an environment that is prone to contamination by rust and other debris including sticky oil deposits.

Therefore, at least annually these drains should be removed for cleaning and inspection/replacement of the wearing parts - especially the diaphragm.

The small cost of this maintenance is repaid by the ongoing savings the user will achieve by reducing air loss, and by the extended life of the drain device

Functional tests & diagnostics

- 1) **Condensate builds up, but no alarm shows.** Press 'TEST'. If the drain operates repeatedly until build-up is cleared, but then build-up occurs again, there is an air lock in the inlet pipe. Check installation parameters.
- 2) **Compressed air passes through the drain.** Clean the valve seat and check/replace diaphragm
- 3) **Condensate isn't cleared, and briefly pressing 'TEST' button produces only a single operation.** The capacitive sensor may be thickly coated in oil/debris. Strip and clean the sensor cover in side the reservoir

Specifications

Model	Description	Pressure	Port size	Seal	Alarms	Body	Voltage options	Operating ambient
ZL1300 & ZL1300RA	Zero-loss drain with capacitive sensors & pilot air operation of the diaphragm seal	15-232 psi	1/2" NPT all round	NBR	Local alarm all models.	Aluminium hard-coated	110VAC	+34F
ZL5000 & ZL5000RA		15-232 psi	3/4" NPT top inlet, 1/2" NPT lower & outlet		Remote alarm contacts RA only		or 230VAC	to +140F

STELSEP, PO box 12127,Scottsdale, AZ, 85267

tel: 602-741-7970 e: info@stelsep.com www.stelsep.com